

B.Y.O.B.

Build Your Own Barrel Smoker Kit



**MAN CRATES
PROJECTS**

COMPONENTS

Everything provided to make your own Barrel Smoker

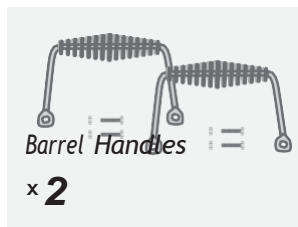
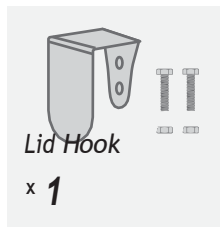
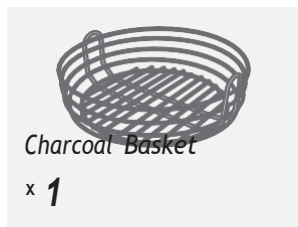
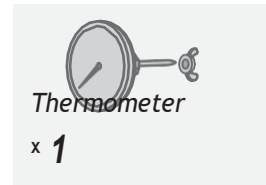
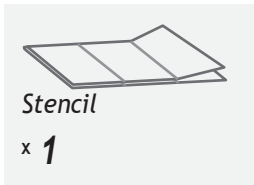
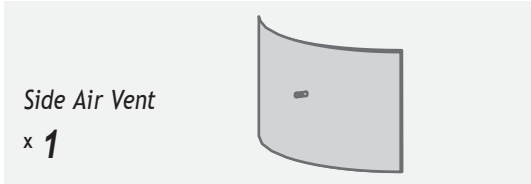
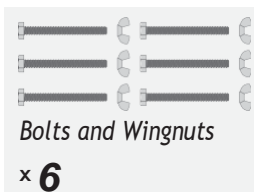
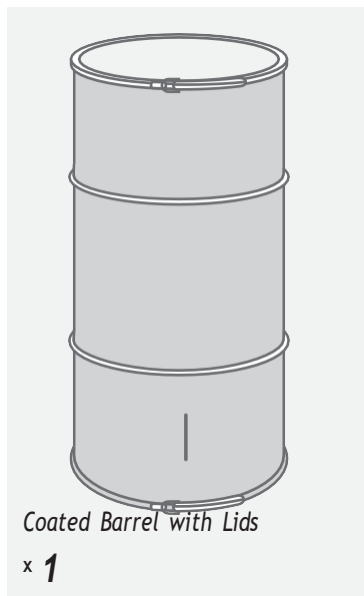

The Barrel

This 16 gallon barrel is made from carbon steel and is coated with a high temperature powder to handle up to 900°F. You'll mainly be using it around 300°F. It's tall enough to hang racks of ribs or stack two layers of delicious meat. Best of all, the unique double open-ended design and lid clamps allow you to set up, seal, and tear down your smoker in no time.

IMPORTANT: Over time, you'll need to season the inside of your barrel to protect it from rust. It's already been coated with a food-safe oil, but you'll want to give another coat before your first light. Once lit, the heat will bake this oil into a seasoning layer like a cast iron pan, and that will seal and protect your barrel.

The Hardware

We've provided grill grates, a charcoal basket, a hanging rack, and all the hardware you'll need for different smoking configurations. Your smoker will stand on hairpin legs, and you'll attach wire-wrapped handles and a lid hook for easy handling. The lid, side vents, and mountable temperature probe will help accurately control heat, and a mountable bottle opener will help accurately control high spirits.

For easy assembly, we've included a stencil since we know geometry wasn't your strong suit. It'll help you mark the holes for mounting components before you breach the barrel with your pilot hole, drill bit, and stepper bit.



This project takes on average
3 hours to complete

You might also need: Eye protection, gloves, a drill, an awl or hammer and nail, and a rat tail file or sandpaper for cleaning up the holes after drilling.

DRILLING HOLES

Preparation for mounting components to the barrel

SafeP first. Whenever you're drilling into the barrel, wear eye protection and gloves. Sharp metal shaving can fly while you're drilling, and they make nasty splinters.



Fig 1

- 1 Unlatch the lids from the barrel to separate components. Use the previous page to confirm you have all parts.
- 2 To build your smoker, you'll be drilling holes in the barrel and both ends. After each hole drilled, follow the procedure outlined on the next page, regardless of the diameter size.

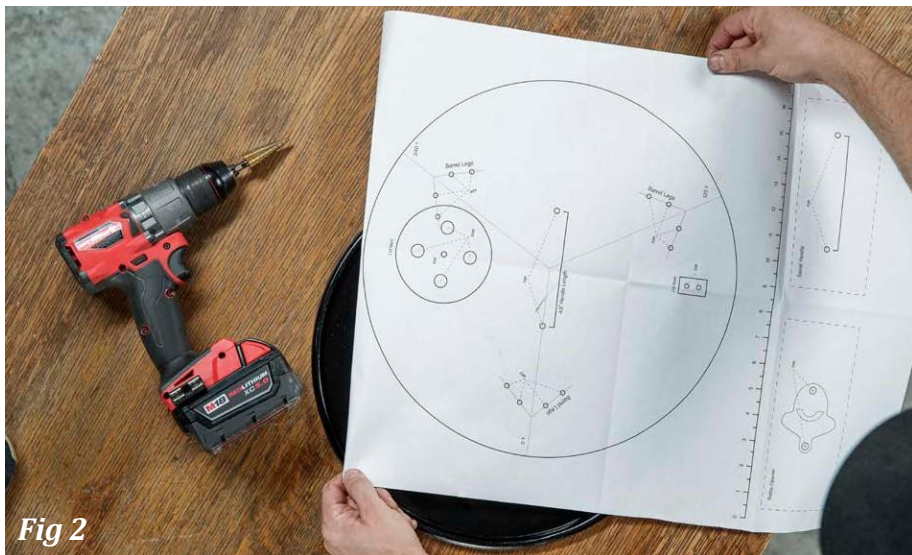

Fig 2

- 3 First, lay the stencil on top of the appropriate work area and find the holes you'll need to drill. Cut the stencil into pieces and tape it in place for easier alignment (Fig 2).

- 4 Using an awl or a nail, lightly tap the circle's center with a hammer to create a small indent for drill positioning (Fig 3).

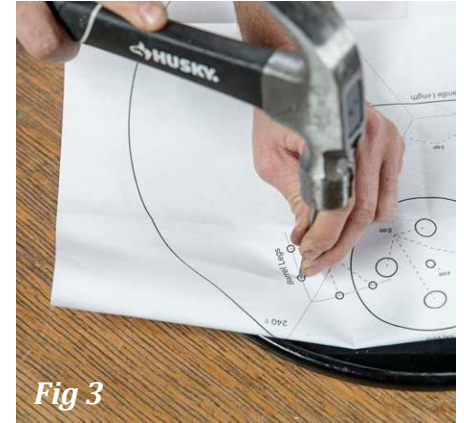

Fig 3

- 5 Using the pilot hole bit, drill a hole through the barrel or lid (Fig 4). This will center the holes you drill with the step bit.



Fig 4

- 6 Next, use the step bit to drill to the final diameter. Each step is marked. Be careful not to drill holes wider than required.

- 7 Finally, drill the hole from the other side of them to clean up any burrs (Fig 5). Don't drill down another step, this is just to clean any rough metal around the hole. You can also use a rat tail file or sandpaper for additional cleaning.



Fig 5

Pro Tip:

The hardware will cover up the roughness of the hole once attached, but cleaning it will make sure the hardware mounts flush.

THE BASE

Mounting legs to the bottom



Fig 6



Fig 7

- 1 Decide which end of the barrel should be the bottom, then lay the stencil over it (Fig 2). Find the areas marked “**leg mounts**” and nailmark through the paper where you’ll need to drill all holes in the barrel. (Fig 3)
- 2 Follow the procedure outlined previously and drill all leg mount holes to **4 mm**.
- 3 Using the attached hardware, mount the **legs** onto the base (Fig 6, 7). Tighten with a screwdriver.

THE LID

Attaching a lid hook, handle, and lid vent

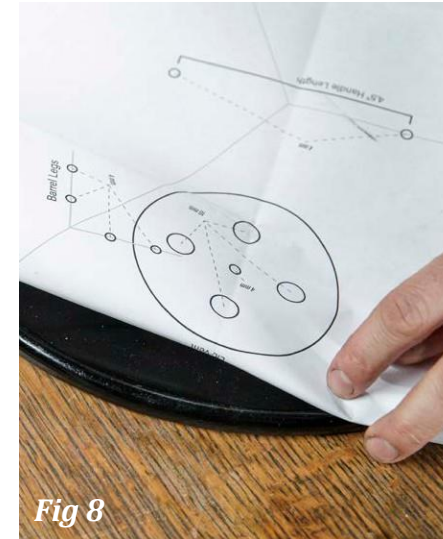

Fig 8

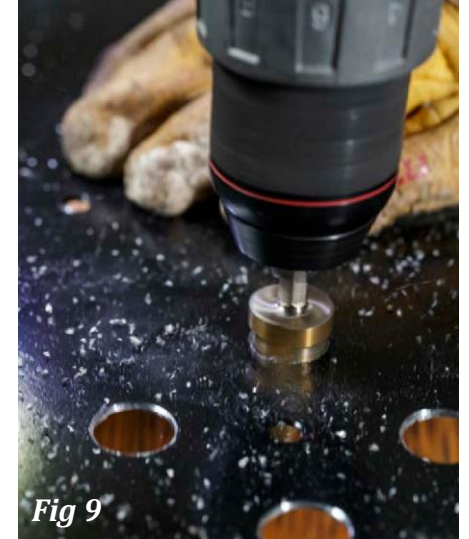

Fig 9



Fig 10



Fig 11

Pro Tip:

Cut stencil into smaller pieces to make marking holes easier. Use tape so it doesn't move once you start marking holes.

1 Flip the barrel over to what will be the lid. Find the areas marked “*lid handle*,” “*lid hook*,” and “*vent*” on the stencil and mark through the paper where you’ll need to drill all holes (Fig 8).

2 Following the same procedure for drilling holes, start with the *lid handle*. Drill both holes to **4 mm**.

The *lid handle* mounts are angled perpendicular to the flat lid, while the barrel handles are angled inward. Use the included hardware to mount the lid handle to the outside of the lid (Fig 11).

3 Drill the *lid hook* holes to **4 mm** diameter.

The *lid hook* attaches on the inside of the lid (Fig 12). Use a screwdriver and the included hardware to mount and tighten.

4 Drill the center hole used to attach the *lid vent* to **4 mm**, then drill 4 surrounding venting holes to **18 mm** (Fig 9).

Mount the vent to the outside of the lid placing the washer between the vent and the lid. Tighten until snug, but loose enough that the vent can freely rotate to open and close (Fig 10).



Fig 12

THE VENT

Controlling air intake

1 Find the channel already cut into the side of the barrel. This is where you’ll mount the *main vent* for controlling air intake. Find the corresponding area on the stencil and mark where you’ll drill all intake vent holes.

2 Drill intake holes to **18 mm** (Fig 13).

3 Use spring washers and wing nuts to mount the vent to the inside of the barrel (Fig 16). To adjust air intake during use, slightly loosen the wing nuts and slide the vent up or down (Fig 14, 15).

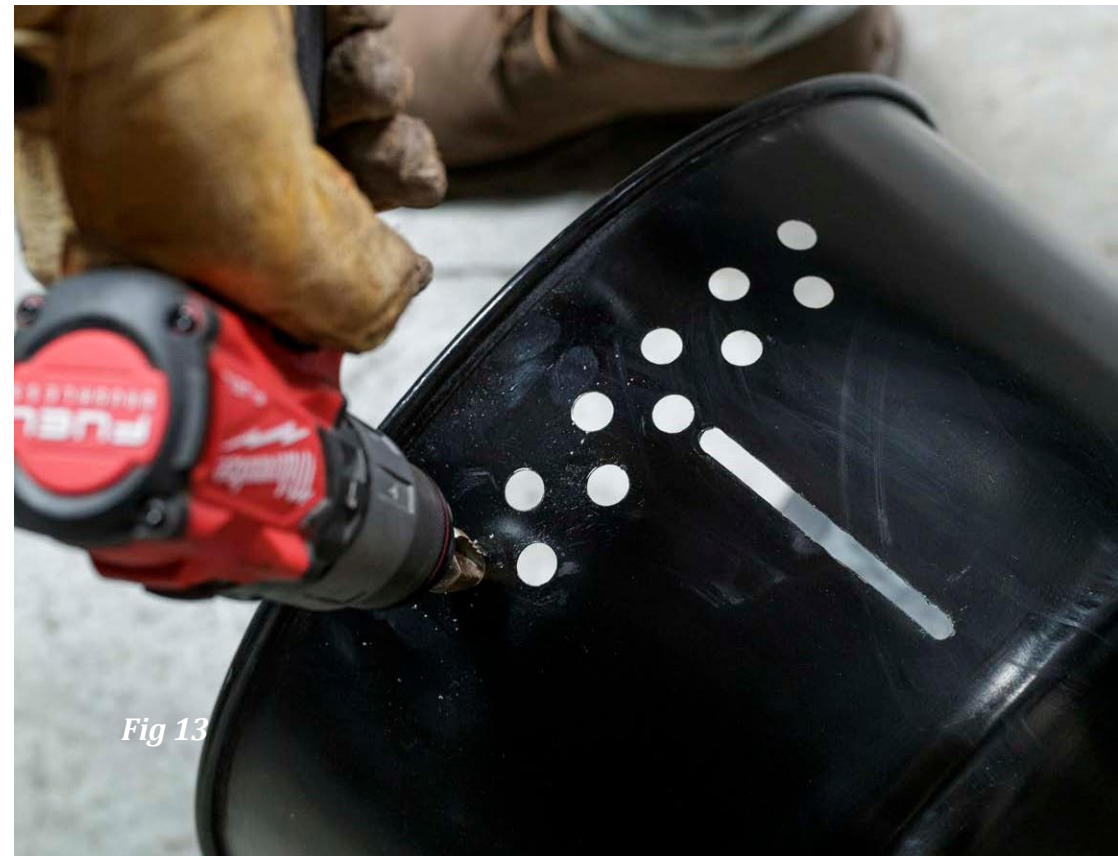

Fig 13



Fig 14



Fig 15

THE BARREL

Adding the handles and grate



Fig 16

- 1 Lay stencil on top of the barrel and mark even thirds around the circumference (Fig 16). This can be arbitrary, or you can anchor one of the thirds with the vent from the last step (Fig 15).
- 2 Measure straight down from each third mark and mark drill holes at **7 in (18 cm)**, right on the first rib of the barrel, and **14 in (35.5 cm)** down from the top lip of the barrel (Fig 17).
- 3 Drill each hole diameter to **6 mm**.
Attach 6 mm bolts and wing nuts through each hole. These bolts will be the supports for the grates and hanging net (Fig 18).
- 4 Do a test assembly to ensure all the grates sit level (Fig 19).



5 Decide handle placement, then mark positions on opposite sides of the barrel. Center the stencil on these marks and place the handle stencil just above the top rib of the barrel (Fig 20).

Drill handle holes to **4 mm** and mount **the handles** with included hardware (Fig 21).

6 We recommend placing the **thermometer** at mid-height of the barrel to get a more average temperature reading.

Drill thermometer hole to **6 mm** and mount thermometer with included hardware (Fig 22).

7 Decide where you'd like to mount the **bottle opener**. Use stencil to position holes (Fig. 23). Drill **4 mm** holes for the bottle opener and mount with included hardware (Fig 24).

THE SETUP

Some of the possible Grill Configurations



Fig 22

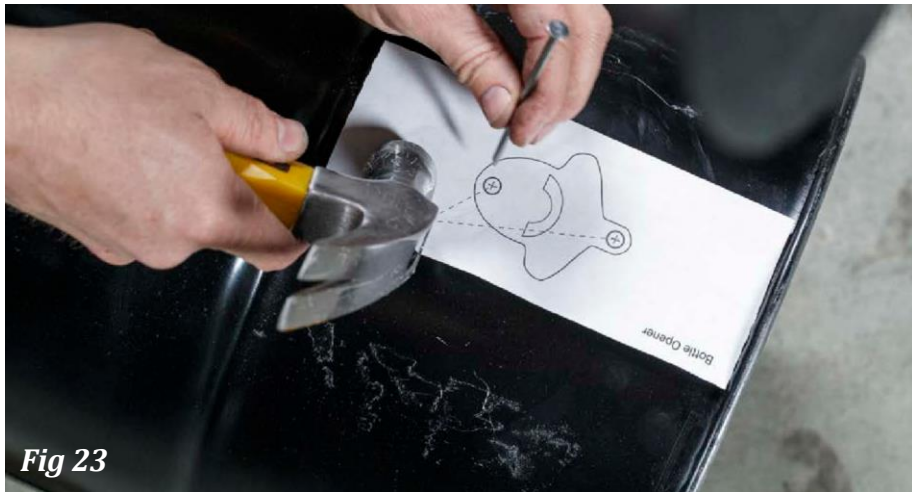
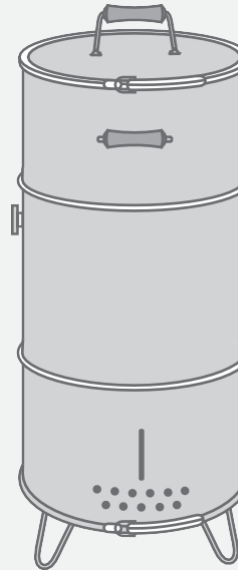

Fig 23

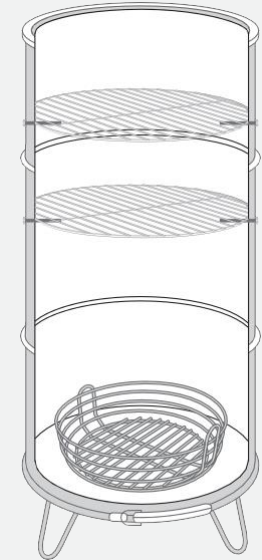

Fig 24

Storage



Double Stack Smoker



Rib Hanging Rack

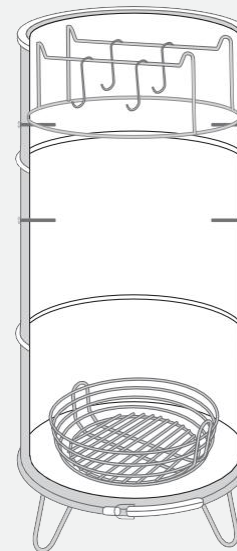

Grill Mode

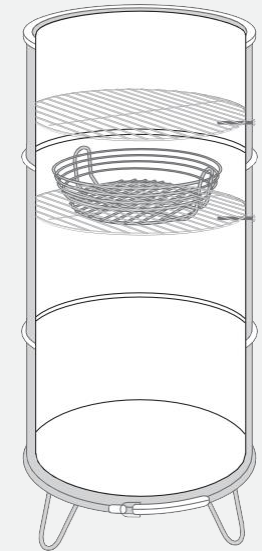

Lighting the Smoker

Use a chimney to light charcoal, or start it directly in the charcoal basket. Place the charcoal basket onto the base and light the coals, or load it up with pre-lit coals (Fig 25).

Lower your barrel over the coals onto the base and latch the barrel ring to secure it to the base (Fig 26). Close the lid and adjust side and lid vents to achieve your ideal smoking temperature, usually between 200°F and 300°F.

Soak your wood chips in water for 20-30 minutes before use, then throw them onto the coals when you're ready to start smoking.



BABY BACK RIBS

Makes 2 full racks of ribs.

Rib Rub

- 2 TB kosher salt
- 2 TB paprika
- 4 tsp granulated garlic
- 4 tsp chile powder
- 2 tsp dry mustard
- 2 tsp black pepper

BBQ Sauce

- 1 cup apple juice
- 1/2 cup ketchup
- 3 TB cider vinegar
- 1 TB soy sauce
- 2 tsp molasses
- 1/2 tsp chile powder
- 1/2 tsp granulated garlic
- 1/2 tsp dry mustard
- 1/4 tsp kosher salt

- 1 Cut each rack of ribs in half, then generously rub them down with the Rib Rub. If the racks aren't too long, you can leave them whole.
- 2 Once the charcoal is going and the hanging rack is installed in the smoker, stab a meat hook between the 2nd and 3rd rib on each rack, then hang each rack in the smoker. Close the lid and smoke at 300°F for 2.5 hours (Fig 29).

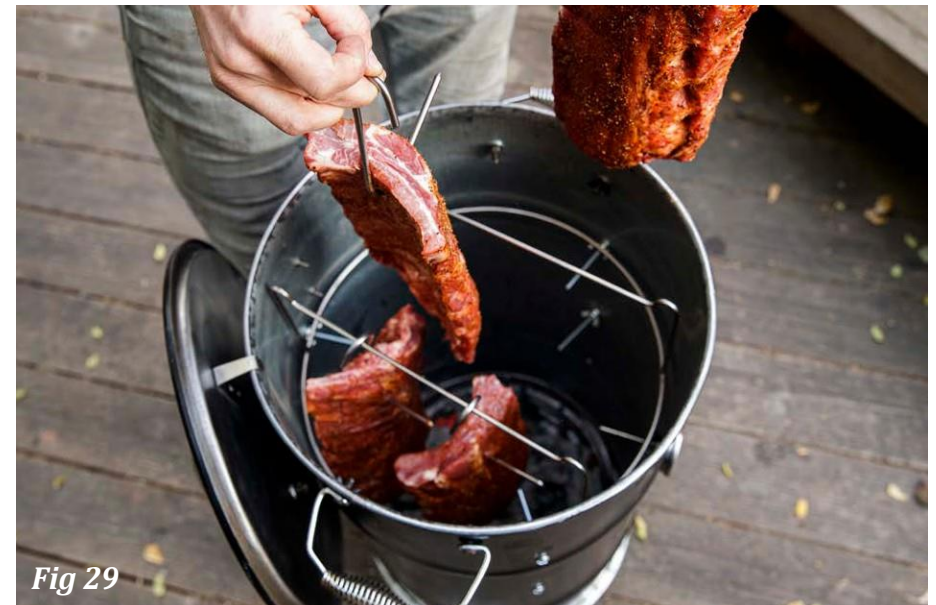

3

While the ribs are smoking, make the sauce by combining all the ingredients in a saucepan. Bring to a boil and let simmer for 10 minutes, then let the sauce cool.

4

Remove the ribs and swap out the hanging rack for the grill grates. Wrap the ribs in tin foil and place back in the smoker for another 30 minutes (Fig 30).

5

Open the tinfoil and slather the ribs with sauce. Place the ribs back inside for another 20-30 minutes.

6

Remove the ribs and slice them up. Slather with more sauce and serve.



Fig 30



Showcase your creation at [facebook.com/mancrates](https://www.facebook.com/mancrates), or find us on Instagram: @mancrates

YOUR NEXT PROJECT AWAITS...

Lure Making Kit



Pinecone Bowie Kit



Home Brewing Kit



Watch Making Kit



Man Crates Project Kits harken back to that honorable do-it-yourself era. We prepare all the gear and guidance, but you'll need to supply the elbow grease. See all our Project Kits at [mancrates.com](https://www.mancrates.com).





MANCRATES.COM/PROJECTS