

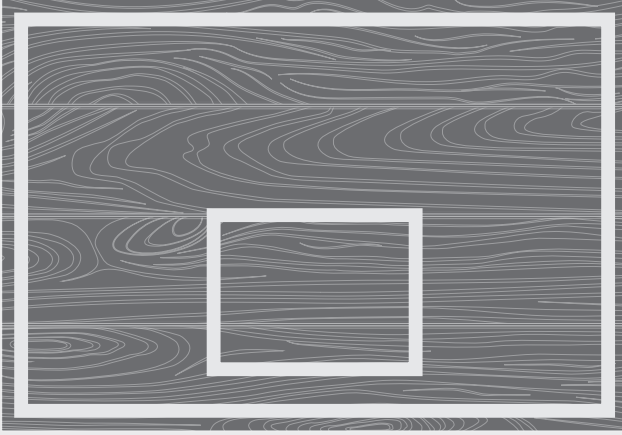

Component Checklist

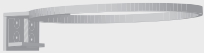

Hardwood Backboard
x1



Breakaway Rim
x1



1" Phillips Head Bolt
x4



Net
x1

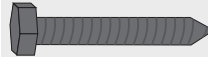

2" Hex Screw
x2

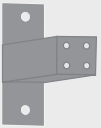

Wall Mount
x1



3/4" Phillips Head Screw
x4



Door Mount
x2



Hex Nut
x4



Synthetic Leather Basketball
x1



3m Felt Pad
x2

Mounting Options

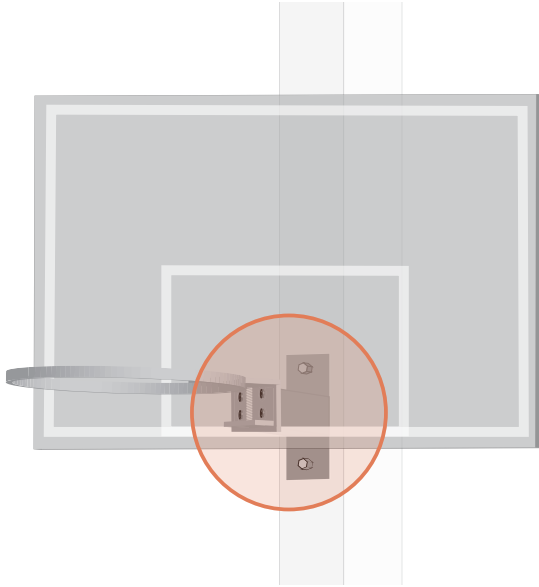

Wall Mounted (P. 3)

Tools You'll Need:

Power Drill
1/4" Drill Bit
Phillips Screwdriver
Stud Finder
Pencil
Socket Wrench

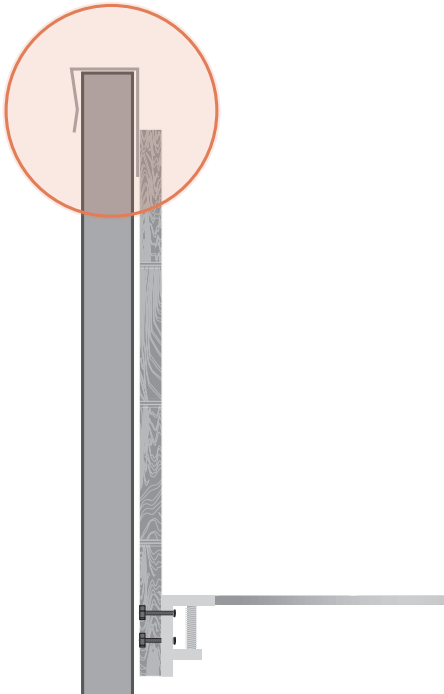

Door Mounted (P. 5)

Tools You'll Need:

Power Drill
1/4" Drill Bit
1/8" Phillips Bit
Phillips Screwdriver
Pencil

Wall Mounted

Components Required

- Hardwood Backboard x1
- Breakaway Rim x1
- Net x1
- Wall Mount x1
- 1" Phillips Head Bolt x4
- 2" Hex Screw x4

This option is designed to be mounted onto a 2x4" stud within your wall.

Do not hang on the rim.

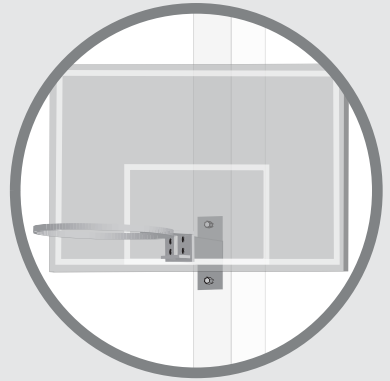

- 1 Once you've selected the ideal location to hang the hoop, use a stud finder to locate the center of the stud. Use a pencil to mark the location of each stud's center, then use a small nail to confirm your findings.
- 2 Align the two holes of the stud mount vertically along the stud's center and raise or lower to determine the final rim height. Make sure to leave at least 24" of vertical clearance for the backboard.

Pencil lightly where the pilot holes should be located along the center of the stud.

Pro-Tip: Most ceilings are eight feet high, so the final rim height will be around six feet.

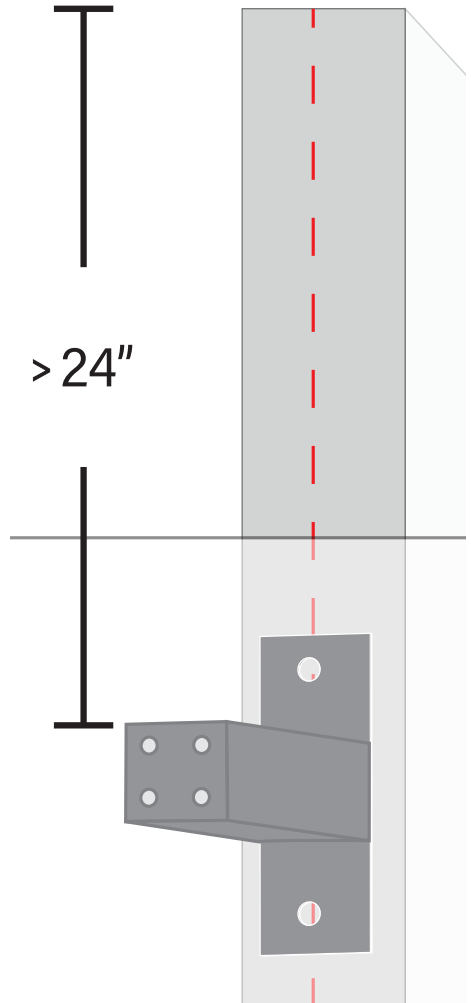

- 3** Use a 1/4" drill bit to drill your pilot holes on the marks.

Align the wall mount holes with the pilot holes on the wall.

Using a socket wrench or nut driver bit, screw both 2" Hex Screw into the holes to attach the mount to the wall.

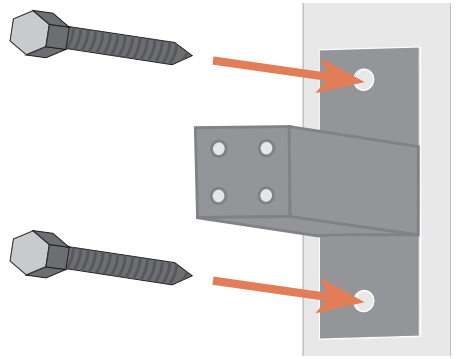

- 4** Insert four 1" Phillips Head Bolts through the holes of the rim and backboard, then screw into mount.

Check to see the rim is level before fully tightening.

Finally, attach the net to the rim

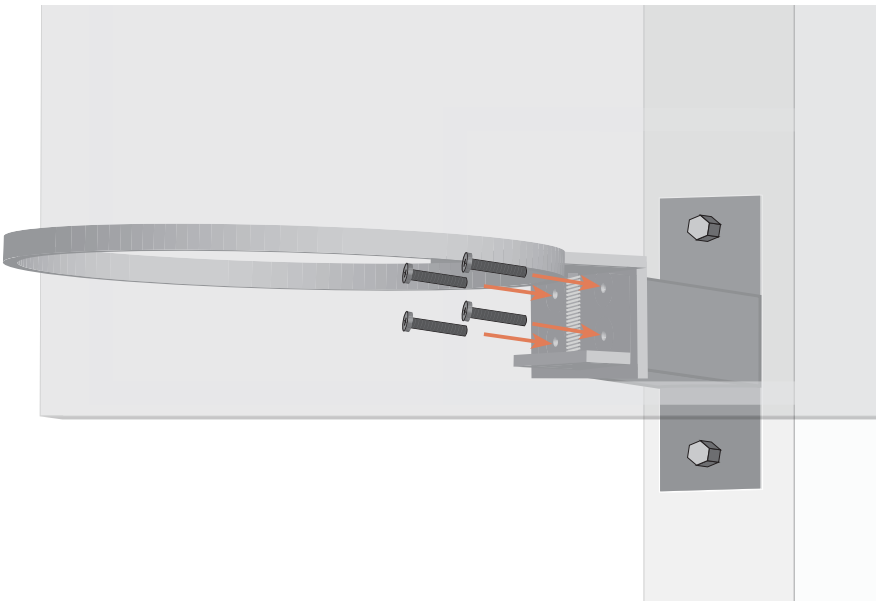

Door Mounted

Components Required

Hardwood Backboard x1

Breakaway Rim x1

Net x1

Door Mount x2

3/4" Phillips Head Screw x4

1" Phillips Head Bolt x4

Hex Nut x4

This mount is designed to be hung on indoor door tops. Ensure that the door mounts will fit the door prior to assembly.

Do not hang on the rim.

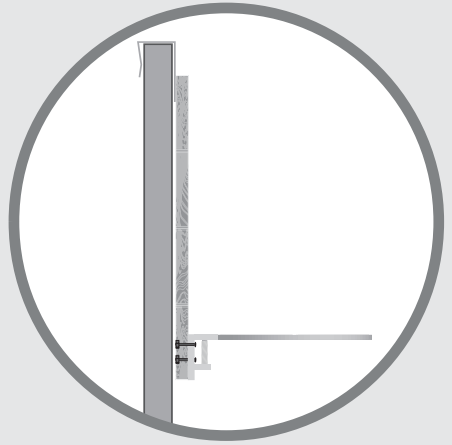

1 Lay the backboard on a flat surface with the printed side facing down.

Place the door mounts along the backboard frame in a position matching the diagram below and mark the two pilot holes.

2 Use a 1/8" drill bit to drill pilot holes on the marks.

Align the mount holes, then use the 3/4" screws to attach the door mounts to the backboard.

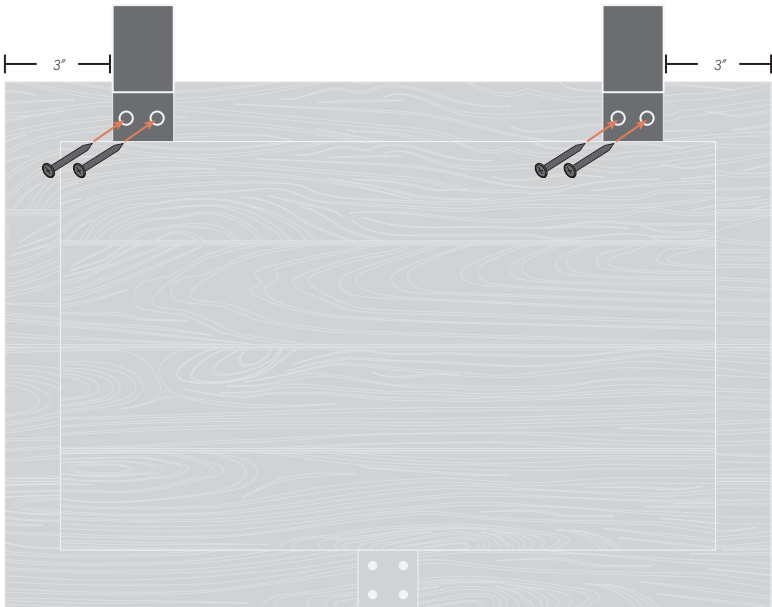

- 3** Remove the adhesive backing from the felt pad and place it onto the rear of the backboard as shown.

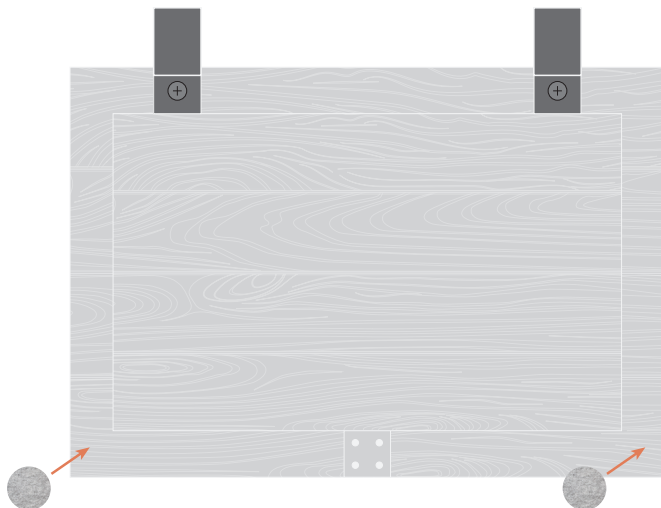

- 4** Insert four 1" Phillips Head Bolts through the holes and screw into nuts on the other side using a wrench and screwdriver.

Check to see the rim is level before fully tightening.

Finally, hang your net onto the rim.



- 5** Place mounts over the door top to hang your assembled basketball hoop.

**MIAMI
CRATES**